

FOR MACHINE VISION AND OTHER INDUSTRIAL APPLICATIONS

Hitachi Black and white CCD camera

KP-M1AN/KP-M1AP

CCD



Compact size and lightweight (about 90cm³ in volume and about 120g in weight) achieved by using the hybrid IC and high density mounting technologies.

Variable speed electronic shutter of eight steps from 1/100 (1/120 for P type) to 1/10000 seconds provided.

Field-on-demand function provides an instantaneous picture at desired external trigger timing.

2/3-inch CCD with a total 410,000-pixels (470,000 pixels for P type) provided to enable high accuracy image processing

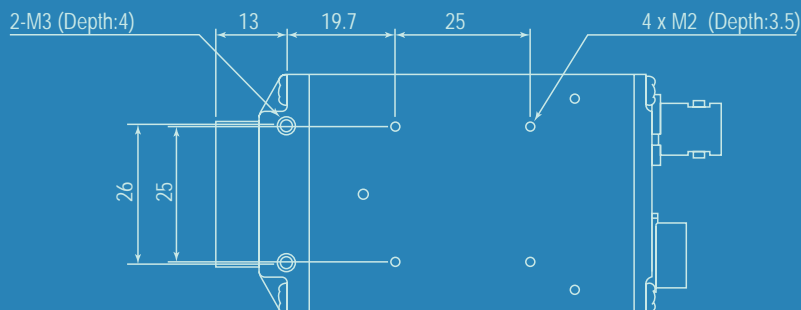
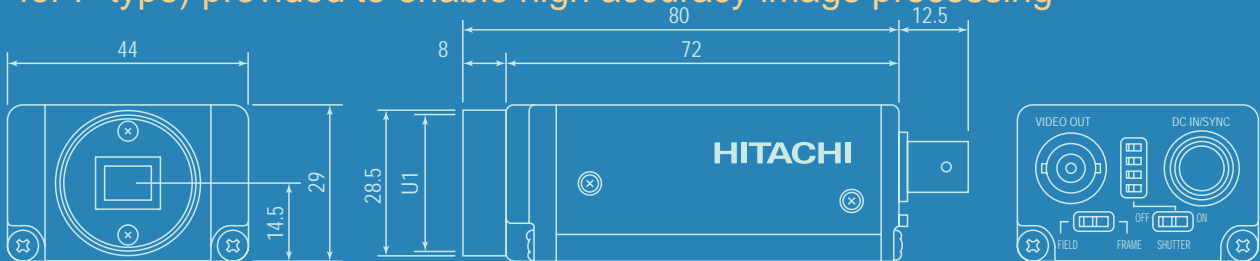

Unit mm

Extremely compact and lightweight

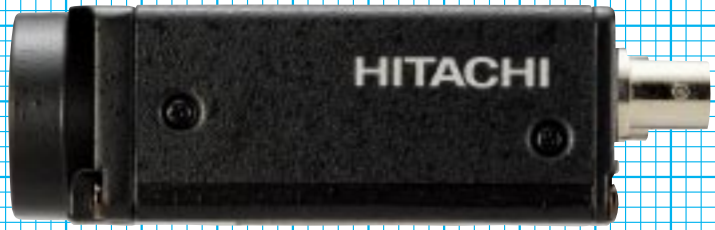

Actual Size

The Hitachi KP-M1A is a black and white camera which uses the latest high grade 2/3-inch image size CCD. Though the KP-M1A is a compact and lightweight camera, it features high sensitivity and high resolution. As the KP-M1A is provided with a variety of functions including the multiple step electronic shutter function, the *restart and reset function, the selectable integration mode, the HD/VD external sync operation, and the non-interlace scan capability, it is most suitable for use with a microscope or an image processing equipment. (*option)



Compact and lightweight

The KP-M1A is small in size and light in weight, while the camera is provided with multiple functions and delivers high performance. The video signal can be obtained only by supplying 12V DC.

High resolution

The KP-M1A uses the latest high grade CCD which has 410,000 pixels and 768(H) x 494(V) effective pixels [CCIR: Number of pixels is 470,000 and number of effective pixels is 752(H) x 582(V)]. The camera features horizontal resolution of 570 (560 for CCIR) TV lines and vertical resolution of 485 (575 for CCIR) TV lines.

2/3-inch image size

The image size is 2/3 inches, which is most popular among cameras for industrial application. As the standard C type lens mounting is provided, the camera can be installed on a microscope.

Multiple step electronic shutter function

The multiple step electronic shutter function is provided. The eight-step shutter speed can be selected from 1/100 (1/120 for CCIR) to 1/10000.

Internal/external sync. Interlace/non-interlace capabilities

The sync system and the scanning system are automatically selected when an external sync signal is supplied.

Field-on-demand function

The image captured at an optional timing by an external trigger signal can be output instantly. The capture time can be adjusted by an external trigger signal and the shutter.

Frame and field integration modes

An integration mode can be switched between the frame mode and the field mode, an appropriate picture can be obtained by a combination of the scanning system, the electronic shutter and the restart and reset function.

Resistant to vibrations

The camera uses aluminum die castings and the camera is designed by taking consideration of vibration-resistant performance.

Shutter function

The shutter speed of the KP-M1A can be selected in eight steps from 1/100 (CCIR: 1/120) to 1/10000 seconds with the switch on the rear. To select the speed, set the SHUTTER ON/OFF switch to ON, then set the speed with the shutter speed select switch.



Shutter speed select switch

SHUTTER ON/OFF switch

Setting of shutter speed

Position									
Speed (second)	Normal 1/60(CCIR) 1/50 (EIA)	1/125	1/250	1/500	1/1000	1/2000	1/4000	1/10000	1/120 (CCIR) 1/100 (EIA)

Relationship among electronic shutter, scanning system, integration mode and video output

Integration mode		Frame Integration mode		Field Integration mode	
		Interlace	Non-interlace	Interlace	Non-interlace
Scanning system					
Relationship between integration time and VIDEOOUT	Integration time				
	VD				
	VIDEO OUT				
Vertical resolution(TV lines)		485 (575)	242 (287)	350 (415)	242 (287)

Field-on-demand function

ONE trigger mode

The shutter is started by the rising edge of the trigger A pulse, and V.SYNC is reset by the falling edge of the trigger A pulse. (After reset, the first field is delivered)
A shutter time is controlled by the duration when the trigger pulse is high.
Only one field image is delivered by one trigger pulse, and a sync signal lasts till the next pulse.

Trigger pulse
5Vp-p +0.5/-1.0Vp-p
Low period: EIA :16.7V or more
CCIR:20V or more
High period: 8U or more

Fixed shutter mode

The shutter is started by the falling edge of the trigger A pulse, and at the same time V.SYNC is reset. (After reset, the first field is delivered)
Only one field is delivered by one trigger pulse, and a sync signal lasts till the next pulse.

Trigger pulse
5Vp-p +0.5/-1.0Vp-p
Low period: EIA :63.5U or more
CCIR:64U or more
High period: EIA :16.7V or more
CCIR:20V or more

TWO trigger mode

V.SYNC is reset by the falling edge of the trigger A pulse. (After reset, the first field is delivered.)
The shutter is started by the rising edge of the trigger B pulse.

Trigger pulse
5Vp-p +0.5/-1.0Vp-p
Trigger A: Low period: EIA :63.5U or more
CCIR:64U or more
High period: EIA :16.7V or more
CCIR:20V or more
Trigger B: Low period: Not specified
High period: 8U or more

External shutter control mode

The shutter is started by the rising edge of the trigger B pulse, the shutter is effective only for the next field of the pulse input. When the trigger B pulse is not supplied, the normal exposure results.
The V.SYNC pulse of the camera is not reset.

Trigger pulse
5Vp-p +0.5/-1.0Vp-p
Low period: Not specified
High period: 8U or more

Field/frame integration

Since the scanning line is read one by one in the frame integration mode, the highest vertical resolution can be obtained in the normal shutter mode. Since the scanning line is read two by two in the field integration mode, sensitivity is almost double in shutter operation in comparison with that in the frame storage mode. The mode is set to the frame integration mode at the factory.

Gamma correction mode

Gamma can be switched between 1.0 and 0.45 with an internal switch. Gamma is set to 1.0 at the factory.

AGC

Gain can be switched between NORM (normal) and AGC. Gain is set to NORM at the factory.

Video output signal

The video signal (1Vp-p/75 ohms) is fed from the VIDEO OUT terminal (BNC) and the DC IN/SYNC terminal (12-pin). However, since the video signal is fed to the terminals from one output amplifier, use either of the terminals.

Camera input signal

Internal sync/2:1 interlace

When an external sync signal is not fed in, the camera is automatically operated in the internal sync (2:1 interlace) mode. The mode is automatically switched between the internal sync mode and the external sync mode.

External Sync (VS, VBS or SYNC)

When the external sync signal of the composite video signal (VS) or the composite sync signal (SYNC) is fed in, the camera is operated in the external sync (2:1 interlace) mode.

External sync (HD/VD)

When HD/VD (5.0Vp-p/High) is fed in to the HD/VD input terminal, the camera is operated in the external sync mode.

$$\begin{aligned} \text{HD: } f_H &= 15,734\text{Hz} \pm 1\% \text{ (EIA)} \\ &= 15,625\text{Hz} \pm 1\% \text{ (CCIR)} \\ \text{VD: } f_V &= 59.94\text{Hz} [f_V = f_H \div 262.5] \text{ (EIA)} \\ &= 50\text{Hz} [f_V = f_H \div 312.5] \text{ (CCIR)} \end{aligned}$$

HD/VD phase

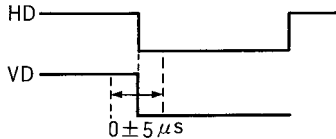

Non-interlace operation

When VD is fed in on the non-interlace condition, the camera is operated in the non-interlace mode.

Connection of DC IN/SYNC (DC input/sync signal) terminal

Use the 12-pin connector for supply of 12VDC, output of a video signal and input of an external sync signal.

Pin locations of 12-pin connector (on camera side)

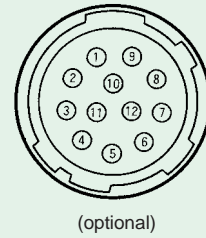

Pin No.	Internal sync	External sync				
		HD VD	Field-on-demand			
			ONE trigger	TWO trigger	Fix trigger	Ext. trigger
1	GND	GND	GND	GND	GND	GND
2	12VDC	12VDC	12VDC	12VDC	12VDC	12VDC
3	Video output (GND)	Video output (GND)	Video output (GND)	Video output (GND)	Video output (GND)	Video output (GND)
4	Video output (Signal)	Video output (Signal)	Video output (Signal)	Video output (Signal)	Video output (Signal)	Video output (Signal)
5	- -	HD input (GND)	- -	- -	- -	HD input (GND)
6	- -	HD input (Signal)	- -	- -	- -	HD input (Signal)
7	- -	VD input (Signal)	Trigger A input (Signal)	Trigger A input (Signal)	Trigger A input (Signal)	VD input (Signal)
8	- -	- -	- -	Trigger B input (GND)	- -	Trigger B input (GND)
9	- -	- -	- -	Trigger B input (Signal)	- -	Trigger B input (Signal)
10	GND	GND	GND	GND	GND	GND
11	12VDC	12VDC	12VDC	12VDC	12VDC	12VDC
12	- -	VD input (GND)	Trigger A input (GND)	Trigger A input (GND)	Trigger A input (GND)	VD input (GND)

Lens mount

The lens mount is of the C mount system, and the flangeback is 17.526mm. Use a lens or an optical system of which length (A) between the flange face of the lens and the end of the screwed section is 8mm or less.

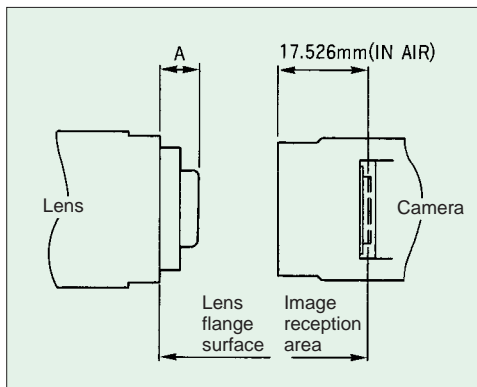

Spectral response characteristics

The KP-M1A is provided with an IR (infrared) cut filter as standard. Normal spectral response characteristics are shown by the dotted line in the figure. However, by removing the IR cut filter is removed, the spectral response can be extended up to the near infrared region.

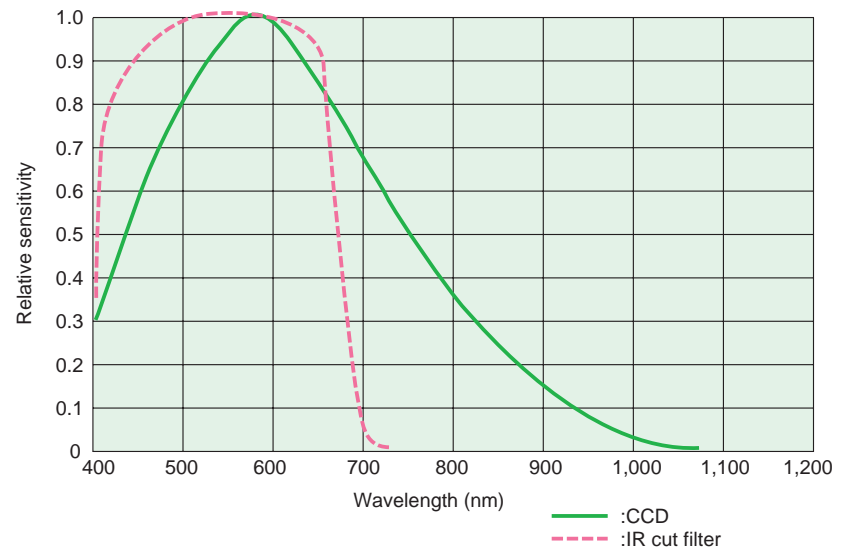

The IR cut filter can be removed by unscrewing the two front screws.

Options

Tripod adaptor TA-M1

When using the camera fixed on the tripod, mount this tripod adaptor on the bottom of the camera. Use the four supplied screws M2 x 5.

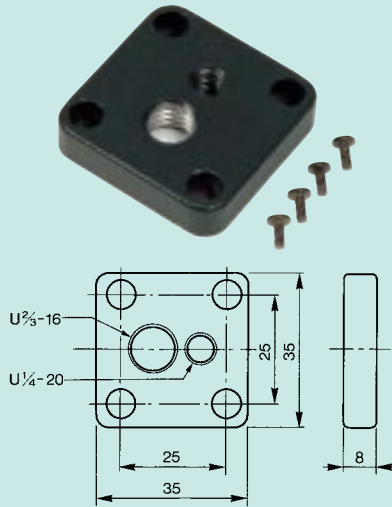

UNIT:mm

Camera cable

Connect this cable to the DC IN/ SYNC Connector of the camera.

	Molded type	Assembly type	Shielded type
2m	C-201KSM	C-201KS	C-201KSS
5m	C-501KSM	C-501KS	C-501KSS
10m	C-102KSM	C-102KS	C-102KSS

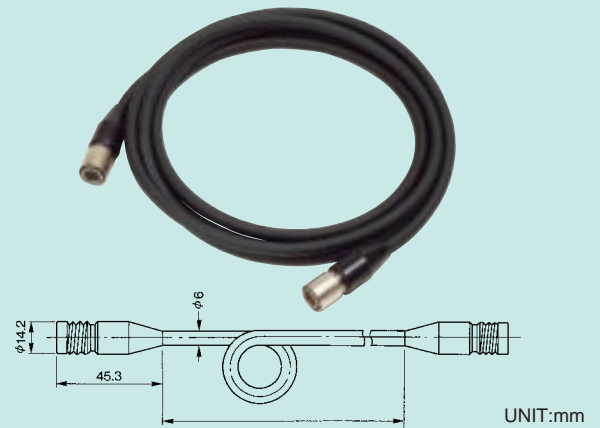

UNIT:mm

DC IN/SYNC plug

Connect this plug to the DC IN/SYNC of the camera.



HR10A-10P-12S (01)
[Made by Hirose Electric Co.,Ltd.]

Junction box JU-M1A

Connect this junction box to the camera using the camera cable.

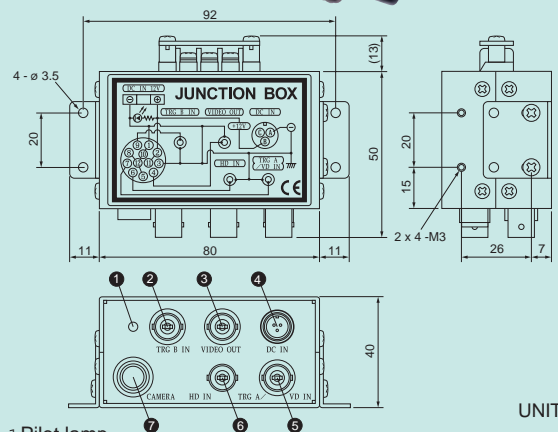

UNIT:mm

- 1 Pilot lamp
- 2 Trigger IN
- 3 VIDEO OUT (video output) [BNC connector]
- 4 DC IN [3 pin]
Connect the AC adaptor AP-130, and 12V DC is supplied.
- 5 VD IN [BNC connector]
When operating the camera by external sync, feed in the VD, VS, VBS or SYNC signal.
- 6 HD IN [BNC connector]
When operating the camera by external sync, feed in the HD signal.
- 7 CAMERA (12-pin) [Multi connector]

AC adaptor AP-130

When operating the camera by a commercial AC power source, use this AC adaptor to supply 12V DC to the camera through the junction box JU-M1A (connected to DC IN).

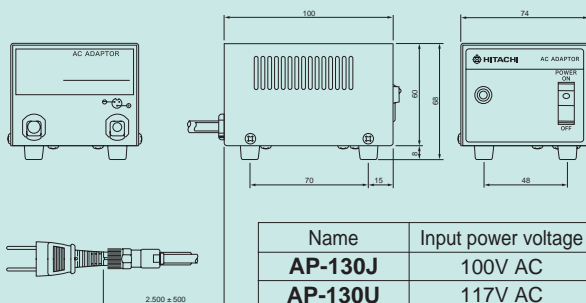

UNIT:mm

System Configuration

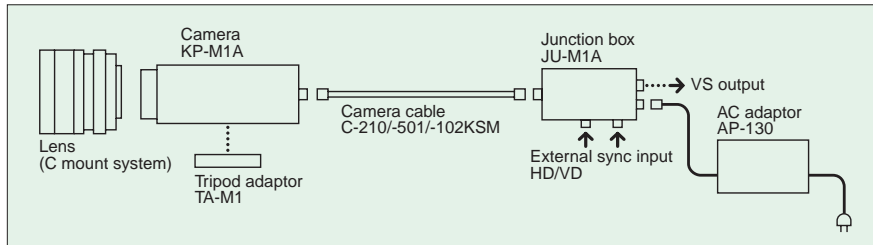

Specifications

	KP-M1AN	KP-M1AP
Signal system	EIA system	CCIR system
Pickup device	Interline transfer CCD	Interline transfer CCD
Number of effective pixels:	768 (H) x 474 (V)	752 (H) x 582 (V)
Sensing area	8.94 x 6.67mm (2/3-inch size)	8.72 (H) x 6.52 (V) (2/3-inch size)
Pixel pitch	11.64 (H) x 13.5 (V) m	11.6 (H) x 11.2 (V) m
Lens mount	C mount	
Flange focal distance	17.526mm	
Scanning frequency	15.734kHz (H), 59.94 (V)	15.625kHz (H), 50Hz (V)
Sync system	Internal sync/external sync (automatic switching)	
Scanning System	2:1 interlaced Non-interlaced (Only in external sync mode)	
External sync input	HD/VD : 2 to 6Vp-p or SYNC : 0.3Vp-p (min. 0.25Vp-p) Input impedance: 1k ohms Frequency deviation ±1% Polarity : Negative	
Video output	VS: 1.0Vp-p/75 ohms (DC cut output)	
Sensitivity	Standard	400 lux, f4 (3200K)
	Minimum	0.3 lux, f1.4 (AGC: ON, gamma: 0.45 without IR cut filter)
Horizontal/vertical resolution	570/485 TV lines	560/575 TV lines
S/N	56dB	
Shutter speed	1/10000, 1/4000, 1/2000, 1/1000, 1/500, 1/250, 1/125, 1/120 (CCIR), 1/100 (EIA), OFF (normal exposure) Above setting are possible by external switch, Set to OFF at factory.	
AGC	Normal gain/AGC : (selectable by internal switch)	
Gamma	Gamma=1.0/0.45 (selectable by internal switch) (set to 1.0 at factory)	
Integration mode	Field or frame integration : Selectable by external switch (set to frame integration mode at factory)	
Field-on-demand	ON/OFF selectable by internal switch (set to OFF at factory)	
Restart and reset operation	ON/OFF selectable by internal points (optional function) (set to OFF at factory) Input: 5Vp-p/1 k ohms	
White clip	Clip level: 1.0Vp-p (excluding SYNC)	
Ambient temperature and humidity	Full specifications	0 to 40°C (32 to 104°F), RH 50 to 70%
	Operating	-10 to 50°C (14 to 122°F), RH 90% or less
	Storage	-20 to 60°C (-4 to 140°F), RH 70% or less
Resistance to vibration	98m/s ²	
Resistance to shock	686m/s ²	
Supply voltage	12V DC ±1V	
Current consumption	220mA approx.	
Dimensions	44 (W) x 29 (H) x 72 (D)mm	
Weight	120g (4.2 oz) approx.	
Composition	Camera head (with IR cut filter)1
	Operation manual1

Dimensions

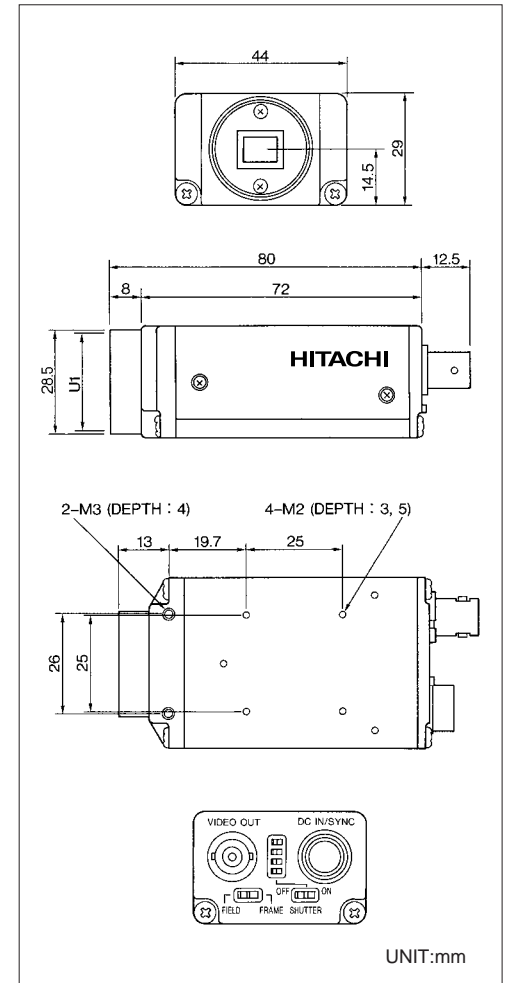

Note

The products and their specifications herein described are subject to change without notice. When placing an order of the products, please make sure whether the information of this material is the latest. Hitachi Kokusai Electric Inc. Warrants that these products meet the standard warranty conditions of Hitachi Kokusai Electric Inc. Hitachi Kokusai Electric Inc. carries out inspection and other quality control of the products within the range required to provide this warranty. It is recommended that to maintain you video product or system in good working order you are advised to discuss with the vendor an appropriate maintenance package to meet your requirements

Hitachi Kokusai Electric Inc.

Head Office : 14-20, Higashi-Nakano 3-chome, Nakano-ku, Tokyo 164-8511, Japan
Phone : (03)5821-5311, Fax : (03) 3368-6111, Fax : (03) 3365-9119

International Operator's Division

1, Kanda Izumi-cho Chiyoda-ku Tokyo 101-0024, Japan
Phone : (03)5821-5311, Fax : (03) 5821-5394

Beijing Office

Beijing Fortune Building 5, Dong San Huan Bei-lu, Chao Yang District, Beijing, 100029 China
Phone : (10) 6590-8755/8756, Fax : (10) 6590-8757

Hitachi Denshi America, Ltd.

Headquarters and Northeast Office : 150 Crossways Park Drive, Woodbury, New York 11797, U. S. A.
Phone : (516) 921-7200, Fax : (516) 496-3718

West Office : 371 Van Ness Way, Suite 120 Torrance, CA, 90501, U. S. A.
Phone : (310) 328-6116, Fax : (310) 328-6252

Midwest Sales : Phone : (877) 326-8104, Fax : (516) 496-3718

Service (734) 721-6180

South Sales : Phone : (877) 326-8105, Fax : (516) 496-3718

Service (678) 937-0201

Parts Center : Phone : (516) 682-4435, Fax : (516) 921-0993

Latin Sales : Phone : (516) 682-4420, Fax : (516) 496-3718

Hitachi Denshi Canada, Ltd.

Head Office : 1 Select Avenue Unit#14 Scarborough, Ontario M1V 5J3, Canada.
Phone : (416) 299-5900, Fax : (416) 299-0450

Eastern Office : 5795 Chermil St. Francois St. Laurent, Quebec H4S 1B6, Canada
Phone : (514) 332-6687, Fax : (514) 335-1664

Ottawa Office : 9 Antares Drive, Nepean, Ontario, K2E 7V5, Canada
Phone : (613) 727-3930, Fax : (613) 825-4253

Hitachi Denshi (Europa) GmbH

Head Office : Westkircher Straße 88, Jügesheim D-63110 Rodgau, Germany
Phone : (6106) 6992-0, Fax : (6106) 1690-6

Hitachi Denshi (U. K.) Ltd.

Head Office : 14 Garrick Industrial Centre, Irving Way, Hendon, London, NW9 6AQ, United Kingdom
Phone : +44 (0)20 8202 4311, Fax : +44 (0)20 8202 2451 sales@hitachi-denshi-uk.com

Leeds Office : Brookfield House, Selby Road, Garforth, Leeds LS25 1NB United Kingdom
Phone : +44 (0)113 287 4400, Fax : +44 (0)113 287 4260 www.hitachi-denshi-uk.com