

## Development Kit Contents

First time *Flea*2 users are required to purchase this kit in addition to purchasing the initial camera:

- 4.5 meter, 9-pin to 9-pin locking IEEE-1394b cable for secure connection
- 4.5 meter, 6-pin to 9-pin locking IEEE-1394a to 1394b cable for secure connection
- IEEE-1394b OHCI PCI Host Adapter 3-port 800Mb/s card
- 1 meter GPIO wiring harness with Hirose HR25 8-pin male connector for easy triggering
- *FlyCapture*® SDK (C/C++ API and device drivers) CD

## Physical Dimensions

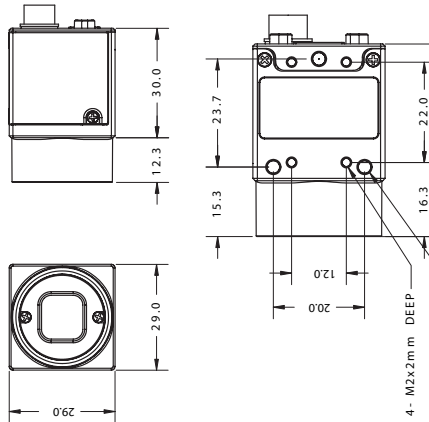

## Camera Specifications

Specification	03S2	08S2	14S3	20S4
<b>Overview</b>	Ultra-compact case-enclosed IEEE-1394b digital camera			
<b>Imaging Sensor</b>	Sony® progressive scan CCDs			
<b>Sensor Model</b>	ICX424 1/3"	ICX204 1/3"	ICX267 1/2"	ICX274 1/1.8"
<b>Sensor Max Pixels</b>	648x488	1032x776	1392x1032	1624x1224
<b>Sensor Pixel Size</b>	7.4 x 7.4µm	4.65 x 4.65µm	4.65 x 4.65µm	4.4 x 4.4µm
<b>A/D Converter</b>	Analog Devices 12-bit analog-to-digital converter			
<b>Video Data Output</b>	8, 16 and 24-bit digital data (see <i>Supported Data Formats</i> )			
<b>Resolutions and FPS</b>	See the <i>Supported Data Formats</i> section			
<b>Partial Image Modes</b>	Pixel binning and region of interest modes available via Format_7			
<b>Interfaces</b>	9-pin IEEE-1394b for camera control and video data transmission 4 general-purpose digital input/output (GPIO) pins.			
<b>Power Requirements</b>	Voltage: 8-32V. Power: less than 2.5W			
<b>Gain</b>	Automatic/Manual/One-Push Gain modes 0dB to 24dB			
<b>Shutter</b>	Automatic/Manual/One-Push Shutter modes 0.01ms to 66.63ms @ 15 FPS Extended shutter modes for exposure times longer than 5 seconds			
<b>Gamma</b>	0.50 to 4.00			
<b>Trigger Modes</b>	DCAM v1.31 Trigger Modes 0, 1, 3, 4, 5 and 14			
<b>Signal To Noise Ratio</b>	Greater than 60dB @ 7.5 FPS			
<b>Dimensions</b>	29mm x 29mm x 30mm (without optics)			
<b>Mass</b>	58 grams (without optics)			
<b>Lens Mount</b>	C-mount			
<b>Camera Specification</b>	IIDC 1394-based Digital Camera Specification v1.31			
<b>Emissions Compliance</b>	Complies with CE rules and Part 15 Class A of FCC Rules			
<b>Operating Temperature</b>	Commercial grade electronics rated from 0° to 45°C			
<b>Storage Temperature</b>	-30° to 60°C			
<b>Warranty</b>	Two years (refer to the <i>Flea2 Technical Reference</i> for full details)			

## Spectral Response (QE)

For full sensor datasheets, including spectral response graphs, go to:  
[www.ptgrey.com/support/kb/index.asp?a=4&q=23](http://www.ptgrey.com/support/kb/index.asp?a=4&q=23)

## Standard Image Formats

● 03S2C ● 03S2M ● 08S2C ● 08S2M

Mode Description	Frames Per Second					
	1.875	3.75	7.5	15	30	60
160x120 YUV444			●●	●●	●●	●
320x240 YUV422	●●	●●	●●	●●	●●	●
640x480 YUV411	●●	●●	●●	●●	●●	●
640x480 YUV422	●●	●●	●●	●●	●●	
640x480 RGB	●●	●●	●●	●●	●●	
640x480 Y8	●●●●	●●●●	●●●●	●●●●	●●●●	●○
640x480 Y16	●●●●	●●●●	●●●●	●●●●	●●●●	
800x600 YUV422		●	●	●	●	
800x600 RGB			●	●	●	
800x600 Y16		●	●	●	●	
800x600 Y8			●	●	●	
1024x768 YUV422	●	●	●	●	●	
1024x768 RGB	●	●	●	●	●	
1024x768 Y16	●●	●●	●●	●●	●●	
1024x768 Y8	●●	●●	●●	●●	●●	

## Camera Features

### Image Acquisition

Feature	Description
<b>IEEE-1394 Bandwidth</b>	800Mb/s pipe allows for full color RGB output at high data rates
<b>Automatic Synchronization</b>	Multiple <i>Flea</i> 2's on the same 1394b bus automatically sync
<b>Fast Frame Rates</b>	Faster standard frame rates, pixel binning and ROI support
<b>Multiple Trigger Modes</b>	Bulb-trigger mode, multiple triggered exposures before readout
<b>Trigger at Full Frame Rate</b>	Overlapped trigger input, image acquisition and transfer

### Image Processing

Feature	Description
<b>Color Conversion</b>	On-camera conversion to YUV411, YUV422 and RGB formats
<b>Image Processing</b>	On-camera control of sharpness, hue, saturation, gamma, LUT
<b>Embedded Image Info</b>	Pixels contain frame-specific info (e.g. shutter, 1394 cycle time)

### Camera and Device Control

Feature	Description
<b>Auto White Balance</b>	Auto and one-push white balance for easy color balancing
<b>Frame Rate Control</b>	Fine-tune frame rates for video conversion (e.g. PAL @ 24 FPS)
<b>Improved Strobe Output</b>	Increased drive strength, configurable strobe pattern output
<b>RS-232 Serial Port</b>	Provides serial communication via GPIO TTL digital logic levels
<b>Memory Channels</b>	Non-volatile storage of camera default power-up settings
<b>Camera Upgrades</b>	Firmware upgradeable in field via IEEE-1394 interface.

### Mechanics and Form Factor

Feature	Description
<b>Industry Standard Design</b>	ASA/ISO-compliant mounting bracket and C-mount lens holder
<b>Jack Screw Connector</b>	1394b cable jack screws provide secure connection

## Standard Image Formats

● 14S3C ● 14S3M ● 20S4C ● 20S4M

Mode Description	Frames Per Second					
	1.875	3.75	7.5	15	30	60
320x240 YUV422	●	●	●	●	●	●
640x480 YUV411	●	●	●	●	●	●
640x480 YUV422	●	●	●	●	●	
640x480 RGB	●	●	●	●	●	
640x480 Y8	●●	●●	●●	●●	●●	●○
640x480 Y16	●●	●●	●●	●●	●●	
800x600 YUV422		●●	●●	●●	●●	
800x600 RGB			●●	●●	●●	
800x600 Y16		●●	●●	●●	●●	
800x600 Y8			●●	●●	●●	
1280x960 YUV422	●●	●●	●●	●●	●●	
1280x960 RGB	●●	●●	●●	●●	●●	
1280x960 Y16	●●●●	●●●●	●●●●	●●●●	●●●●	
1280x960 Y8	●●●●	●●●●	●●●●	●●●●	●●●●	
1600x1200 YUV422	●	●	●	●	●	
1600x1200 RGB	●	●	●	●	●	
1600x1200 Y16	●●	●●	●●	●●	●●	
1600x1200 Y8	●●	●●	●●	●●	●●	

## Camera Interface

### IEEE-1394b Connector and Cables

The *Flea*2 has a standard 9-pin IEEE-1394b connector that is used for data transmission, camera control and powering the camera. The maximum 1394b cable length between any 1394 node (e.g. camera to PCI card) is 4.5m, as specified by the IEEE-1394 standard. Use standard, shielded twisted pair copper cables.

### General Purpose I/O Connector

The *Flea*2 has a Hirose HR25 8-pin general purpose input/output (GPIO) female connector on the back of the case (P/N: HR25-7TR-8SA). The FL2-DEVKIT includes a one (1) meter long wiring harness equipped with a male connector (P/N: HR25-7TP-8P, Digilkey P/N: HR702-ND). Wires are color coded or labelled according to the table below to indicate functionality.

Diagram	Pin	Function	Description
	1	IO0	Input / Output (default: Trigger_Src)
	2	IO1	Input / Output
	3	IO2	Input / Output / RS232 Transmit (TX)
	4	IO3	Input / Output / RS232 Receive (RX)
	5, 6	GND	
	7	Vext	Allows the camera to be powered externally. Voltage limit: 8 to 30V, Current limit: 1A
	8	+3.3V	Power external circuitry up to a total of 150mA
	To configure the GPIO pins, consult the "General Purpose Input / Output" section of the <i>PCR IEEE-1394 Digital Camera Register Reference</i> .		

**Inputs** can be configured to accept external trigger signals. **Outputs** can be configured to send an output signal or strobe pulse. Refer to the *Flea2 Technical Reference* for detailed GPIO electrical characteristics.

### Status LED

<b>Steady on</b>	camera is receiving power and initialized
<b>Steady on and very bright</b>	camera is acquiring and transmitting images
<b>Flashing bright, then brighter</b>	camera registers are being accessed
<b>Steady or slow flashing on and off</b>	camera firmware updated (requires power cycle), or possible error/problem

# 1 Installation

## 1. Recommended System Configuration

- Windows XP Service Pack 1
- 512MB of RAM
- Intel Pentium 4 2.0GHz or compatible processor
- AGP video card with 128MB video memory
- PCI Express slot and I394b card (not included) (32-bit slot required)
- Microsoft Visual C++ 6.0 (to compile and run example code)



## 2. Electrostatic Precautions and Camera Care

- Users who have purchased a bare board camera should:
  - Either handle bare handed or use non-chargeable gloves, clothes or material. Also use conductive shoes.
  - Install a conductive mat on the floor or working table to prevent the generation of static electricity.
- When handling the camera unit, avoid touching the lenses. To clean the lenses, use a standard camera lens cleaning kit or a clean dry cotton cloth. Do not apply excessive force.
- To clean the imaging surface of your CCD, follow the steps outlined in [www.ptgrey.com/support/kb/index.asp?a=4&q=66](http://www.ptgrey.com/support/kb/index.asp?a=4&q=66).
- Extended exposure to bright sunlight, rain, dusty environments, etc. may cause problems with the electronics and the optics of the system.
- Avoid excessive shaking, dropping or mishandling of the device.

# 2 Installation

## 3. Install the IEEE-1394b PCI card

- Place the IEEE-1394b PCI card in an open PCI slot.
- Connect the 4-pin connector on the card to the PC power supply.
- Turn the computer back on and log into Windows.
- In most cases, the Windows IEEE-1394 drivers will be automatically installed for the card, with no user input required. However, in some cases the *Found New Hardware Wizard* will appear. Follow the prompts given by the Wizard to install the card.
- Open Windows Device Manager by going to the Control Panel > System > Hardware tab > Device Manager. Ensure that the PCI card is properly installed as an *IEEE 1394 Bus host controller*.



## 4. Install the FlyCapture® Software and Drivers

- Insert the software CD-ROM. If the Installation Wizard does not automatically run, browse to your CD-ROM directory and run *setup.exe*.
- Follow the installation instructions to install the software.



### IMPORTANT NOTE for Windows XP Users

A dialog will appear prompting you to install the **PGR1394b-PRO** driver. We strongly recommend doing this in order to take full advantage of I394b 800Mb/s speeds. See this Knowledge Base article for further information: [www.ptgrey.com/support/kb/index.asp?a=4&q=171](http://www.ptgrey.com/support/kb/index.asp?a=4&q=171)

# 3 Installation

## 5. Installing the Tripod Mounting Bracket (optional)

- The ASA and ISO-compliant tripod mounting bracket for the *Flea®2* attaches to the camera using the included M2x5 screws.

## 6. Connect the I394b PCI Card and Cable to the Camera

- Plug the 4.5 meter, 9-pin to 9-pin, IEEE-1394b cable into the I394b PCI card and the *Flea2* I394b connector; the cable jack screws can be used for a secure connection. **NOTE:** The camera relies on the 9-pin I394b cable to provide power. If using an interface card other than that provided, ensure that adequate power is provided.
- If the Microsoft Windows "*Found New Hardware Wizard*" appears, proceed to Step 7. Otherwise, proceed to Step 8.

## 7. Install the PGRCAM Driver

- Proceed to Step 8 if the PGR1394b-PRO driver has been installed.
- Click "*Install from a list or specific location*" and click "*Next*".
- Select "*Don't search. I will choose the driver to install*" and "*Next*".
- Click "*Have Disk*" and browse to *C:\Program Files\Point Grey Research\PGR FlyCapture\driver*, click "*Open*", then "*OK*".
- Select the camera model and click "*Next*".
- You will be prompted to continue installation - click "*Continue Anyway*" then "*Finish*" to complete installation.

# 4 Installation

## 8. Confirm Successful Installation

- Check the Device Manager to confirm that installation was successful (PGRCAM driver install only). Go to the *Start* menu, select *Run* and enter "*devmgmt.msc*".
- To test the camera's image acquisition capabilities, run the FlyCap demo program. From the *Start* menu, select *All Programs > Point Grey Research > PGR FlyCapture > FlyCap.exe*.

# 5 Troubleshooting

The FlyCapture® User Guide and other technical references can be found in the *Programs > Point Grey Research > PGR FlyCapture > Documentation* directory. Our on-line Knowledge Base ([www.ptgrey.com/support/kb/](http://www.ptgrey.com/support/kb/)) also addresses the following problems:

- Article 21: Troublesome hardware configurations
- Article 88: Vertical bleeding or smearing from a saturated portion of an image
- Article 91: PGR camera not recognized by system and not listed in Device Manager
- Article 93: My laptop's IEEE-1394 port or PCMCIA card doesn't supply power to my camera
- Article 145: Image discontinuities or horizontal tearing of images when displayed on monitor
- Article 171: Performance of I394 devices may decrease after installing Windows XP SP2
- Article 188: Image data acquired by my camera is corrupt and displayed images are broken
- Article 189: Image capture freezes after a period of successful image capture.

## Contacting Point Grey Research

**Email:** For all general questions about Point Grey Research please contact us at [info@ptgrey.com](mailto:info@ptgrey.com).

For technical support (existing customers only) contact us at [www.ptgrey.com/support/contact/](http://www.ptgrey.com/support/contact/).

**Main Office:** **Mailing Address:** **Tel:** +1 (604) 730-9937  
Point Grey Research, Inc.  
8866 Hudson Street **Fax:** +1 (604) 732-8231  
Vancouver B.C. Canada **Email:** [sales@ptgrey.com](mailto:sales@ptgrey.com)  
V6P 4N2

**Knowledge Base:** Find answers to commonly asked questions in our knowledge base at [www.ptgrey.com/support/kb/](http://www.ptgrey.com/support/kb/).

**Downloads:** Users can download the latest manuals and software from [www.ptgrey.com/support/downloads/](http://www.ptgrey.com/support/downloads/).



POINT GREY  
RESEARCH

## Flea®2

IEEE-1394b Digital Camera



### Getting Started Manual

Document revised April 12, 2007

Copyright © Point Grey Research Inc. 2007. All rights reserved.  
PGR, the Point Grey Research, Inc. logo, Flea and FlyCapture are trademarks of Point Grey Research, Inc. in Canada and other countries.